

REV.	ECN NO.	DESCRIPTION	DRAW	APPD.	DATE
A	---				

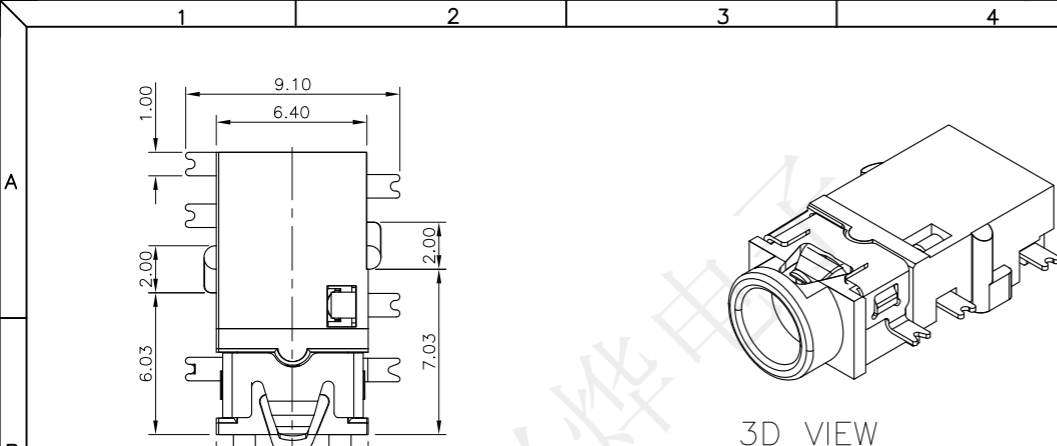

3D VIEW

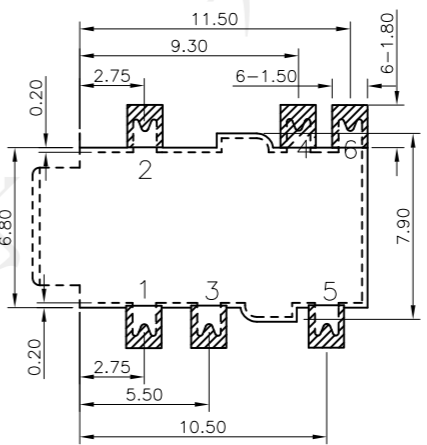
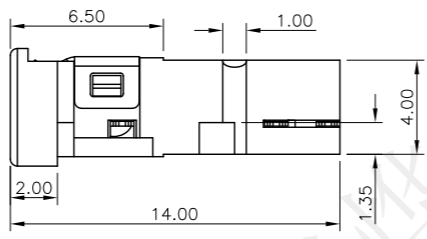
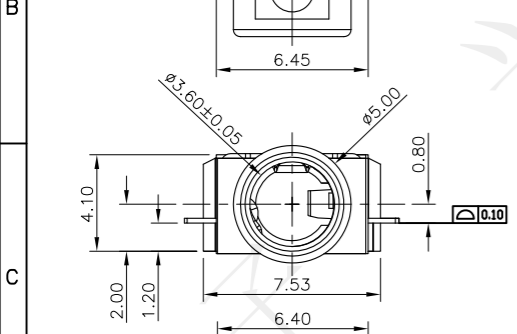
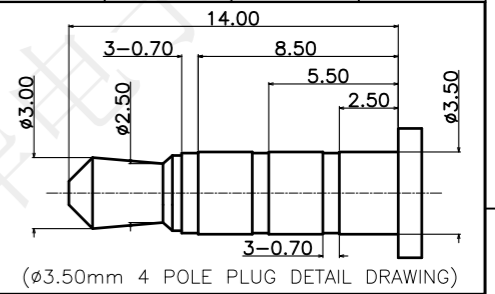

P.C.B LAYOUT TOP VIEW



受控文件

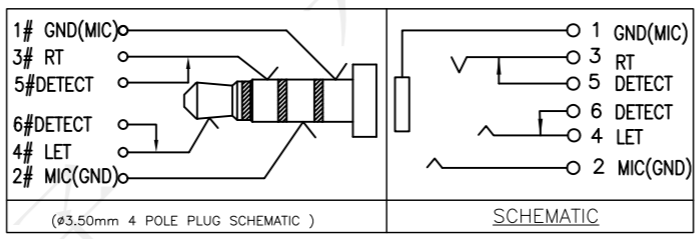
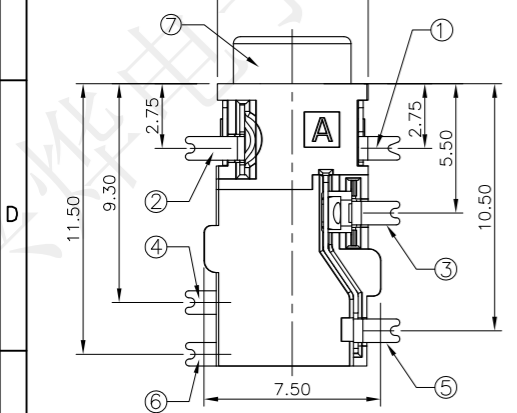

SCHEMATIC

NOTES:

- REQUEST OF THE SPECIFICATION:
 - CONTACT CURRENT RATING: 1A.;
 - CONTACT RESISTANCE: 100 mΩ MAX.;
 - INSULATION RESISTANCE: 100MΩ MIN.;
 - DIELECTRIC WITHSTANDING: 500V AC MIN.;
 - DURABILITY: 5,000 CYCLES MIN.;
 - CONNECTOR MATING FORCES: 29.8N (3.00Kgf) MAX.;
 - CONNECTOR UNMATING FORCES: 2.98N(0.30Kgf) MIN.;

ITEM	NAME	Q'TY	DESCRIPTION	NOTE
7	HOUSING	1	PA9T COLOR BLACK	
6	TERMINAL 6#	1	SUS304; NICKEL UNDER PLATING OVERALL,GOLD PLATING ON SOLDER AREA ;GOLD PLATING ON CONTACT AREA	T=0.20
5	TERMINAL 5#	1	SUS304; NICKEL UNDER PLATING OVERALL,GOLD PLATING ON SOLDER AREA ;GOLD PLATING ON CONTACT AREA	T=0.20
4	TERMINAL 4#	1	SUS304; NICKEL UNDER PLATING OVERALL,GOLD PLATING ON SOLDER AREA ;GOLD PLATING ON CONTACT AREA	T=0.20
3	TERMINAL 3#	1	SUS304; NICKEL UNDER PLATING OVERALL,GOLD PLATING ON SOLDER AREA ;GOLD PLATING ON CONTACT AREA	T=0.20
2	TERMINAL 2#	1	PHOSPHOR BRONZE; NICKEL UNDER PLATING OVERALL,GOLD PLATING ON SOLDER AREA ;GOLD PLATING ON CONTACT AREA	T=0.20
1	TERMINAL 1#	1	SUS304; NICKEL UNDER PLATING OVERALL,GOLD PLATING ON SOLDER AREA ;GOLD PLATING ON CONTACT AREA	T=0.20

深圳市兴烨电子有限公司
Shenzhen XingYe Electronics co., Ltd

TOLERANCE

X.X	±0.30	X.°	±2°
.XX	±0.20	.X°	±1°
.XXX	±0.10	.XX°	±0.5°

UNITS mm

APPD: 陈爱光
CHED: 施立敏
DRAW: 马洪飞

Series Name :		
Product Name :	PJ-35A028沉板全贴正编带	
Part NO:	PJX22038	
SCALE	SHEET	REV.
1:1	1/1	A1