

受控文件

REV.	ECN NO.	DESCRIPTION	DRAW	APPD.	DATE
A	---				

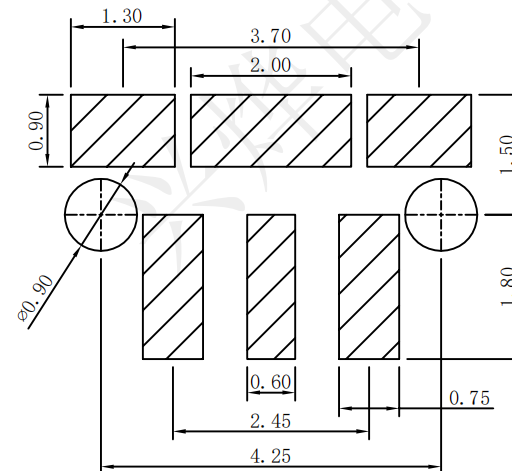

PCB LAYOUT

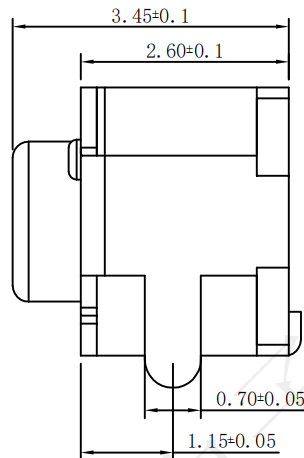
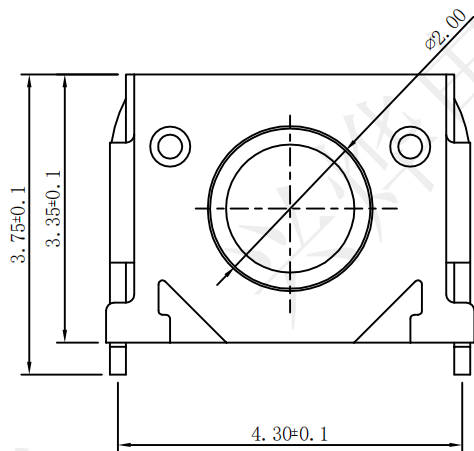
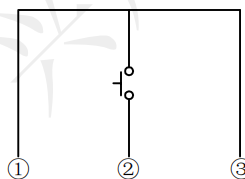
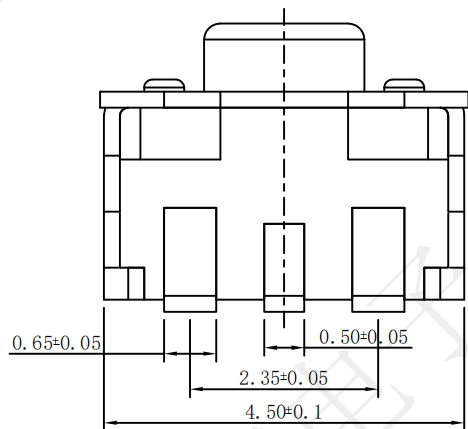

CIRCUIT DIAGRAM
回路图



SPECIFICATION:
 Operating temperature: -25 °C ~ 70 °C
 Rated loading: DC 12V 50mA
 Contact resistance: 100mΩ Max
 Insulation resistance: 100MΩ Min
 Withstanding voltage: AC 250V (50Hz) /min
 Operating force: 160±30gf Max
 Electrical Life: 100000 cycles

⑤	盖板	1PCS	磷铜	电镀: 银
④	按钮	1PCS	LCP	白色
③	簧片	1PCS	不锈钢	银色
②	底座	1PCS	LCP	黑色
①	卡件	1PCS	磷铜	电镀: 银
序列号	名称	数量	材料	备注

深圳市兴烨电子有限公司
 ShenZhen XingYe Electronics co., Ltd

Series Name :
 Product Description :
 3*5*3.4笑脸开关160G白头编带

TOLERANCE		APPD: 陈爱光
XX ±0.30	X° ±2°	CHED: 施立敏
.XX ±0.20	.X° ±1°	
.XXX ±0.10	.XX° ±0.5°	DRAW: 马洪飞
UNITS	mm	

Part NO: TSZ22030

SCALE	SHEET	REV.
1:1	1/1	A1